

**PF4MNB, PF4MNP
FAN COIL UNITS
SIZES 018 TO 061**

Installation Instructions

NOTE: Read the entire instruction manual before starting the installation.

Safety Considerations

Improper installation, adjustment, alteration, service, maintenance, or use can cause explosion, fire, electrical shock, or other conditions which may cause death, personal injury or property damage. Consult a qualified installer, service agency, or your distributor or branch for information or assistance. The qualified installer or agency must use factory-authorized kits or accessories when modifying this product. Refer to the individual instructions packaged with kits or accessories when installing.

Follow all safety codes. Wear safety glasses, protective clothing and work gloves. Have a fire extinguisher available. Read these instructions thoroughly and follow all warnings or cautions included in literature and attached to the unit. Consult local building codes and the current editions of the National Electrical Code (NEC) NFPA 70.

In Canada, refer to the current editions of the Canadian Electrical Code CSA C22.1.

Recognize safety information. This is the safety-alert symbol . When you see this symbol on the unit and in instruction manuals, be alert to the potential for personal injury.

Understand the signal words **DANGER**, **WARNING**, and **CAUTION**. These words are used with the safety-alert symbol. **DANGER** identifies the most serious hazards which **will** result in severe personal injury or death. **WARNING** signifies hazards which **could** result in personal injury or death. **CAUTION** is used to identify unsafe practices which **may** result in minor personal injury or product and property damage. **NOTE** is used to highlight suggestions which **will** result in enhanced installation, reliability, or operation.

 **WARNING**

ELECTRICAL OPERATION HAZARD

Failure to maintain proper clearances could result in personal injury or death.

Before installing or servicing unit, always turn off all power to unit. There may be more than 1 disconnect switch. Turn off accessory heater power if applicable.

 **CAUTION**

CUT HAZARD

Failure to follow this caution may result in personal injury.

Sheet metal parts may have sharp edges or burrs. Use care and wear appropriate protective clothing, safety glasses and gloves when handling parts.

Table of Contents

Safety Considerations	1
Table of Contents	1
Introduction	1
Heater Packages	1
Installation	2
Air Ducts	5
Electrical Connections	5
Table 1 – Fan Speed Selection	7
Refrigerant Tubing Connection and Evacuation	7
Refrigerant Flow-Control Device	7
Condensate Drains	7
Accessories	8
Sequence of Operation	8
Start-Up Procedures	9
Care and Maintenance	9
Table 2 – Air Delivery Performance Correction Component Pressure Drop (in. wc) at Indicated Airflow (Dry-to-Wet Coil)	9
Table 3 – Factory-Installed Filter Static Pressure Drop (in. wc)	9
Table 4 – Electric Heater Static Pressure Drop (in. wc)	10
Table 5 – PF4MNP Airflow Performance (CFM)	10
Table 6 – PF4MNB Airflow Performance (CFM)	11

Introduction

PF4M models are R-410A Fan Coils designed for installation flexibility. These units leave the factory compliant with low leak requirements of less than 2% cabinet leakage rate at 0.5 inches W.C. and 1.4% cabinet leakage rate at 0.5 inches W.C. when tested in accordance with ASHRAE 193 standard.

A TXV is used on PF4MNP (018-060) and PF4MNB(019-061). All these fan coils use a multi-tap ECM motor for efficiency. The units have been designed for upflow, downflow (kit required), and horizontal orientations, including manufactured and mobile home applications.

These units require a field supplied air filter, and are designed specifically for R-410A refrigerant air conditioners and heat pumps as shipped. These units are available for systems of 18,000 through 60,000 BTU/h nominal cooling capacity. Factory-authorized, field-installed electric heater packages are available in sizes 5 through 30kW. See Product Data literature for all available accessory kits.

Heater Packages

This unit may or may not be equipped with an electric heater package. For units not equipped with factory-installed heat, a factory-approved, field-installed, UL listed heater package is available from your equipment supplier. See unit rating plate for a list of factory-approved heaters. Heaters that are not factory approved could cause damage which would not be covered under the equipment warranty. If fan coil contains a factory-installed heater package, minimum circuit ampacity (MCA) and maximum fuse/breaker may be different than units with a same size field-installed accessory heater. The differences is not an error and is due to calculation difference per UL guidelines.

Installation

Check Equipment

Unpack unit and move to final location. Remove carton taking care not to damage unit.

NOTE: If the door gasket is damaged or missing, the unit may not meet the ASHRAE 193 standard for cabinet air leakage. Contact your supplier and order kit #344994-751.

Inspect equipment for damage prior to installation. File claim with shipping company if shipment is damaged or incomplete. Locate unit rating plate which contains proper installation information. Check rating plate to be sure unit matches job specifications.

Mount Unit

Unit can stand or lie on floor, or hang from ceiling or wall. Allow space for wiring, piping, and servicing unit.

IMPORTANT: When unit is installed over a finished ceiling and/or living area, building codes may require a field-supplied secondary condensate pan to be installed under the entire unit. Some localities may allow as an alternative, the running of a separate, secondary condensate line. Consult local codes for additional restrictions or precautions.

NOTE: Nuisance sweating may occur if the unit is installed in a high humidity environment with low airflow.

Upflow Installation

If return air is to be ducted through a floor, set unit on floor over opening and use 1/8 to 1/4-in (3 to 6 mm) thick fireproof resilient gasket between duct, unit, and floor.

Side return is a field option on slope coil models. Cut opening per dimensions (Fig. 1). A field-supplied bottom closure is required.

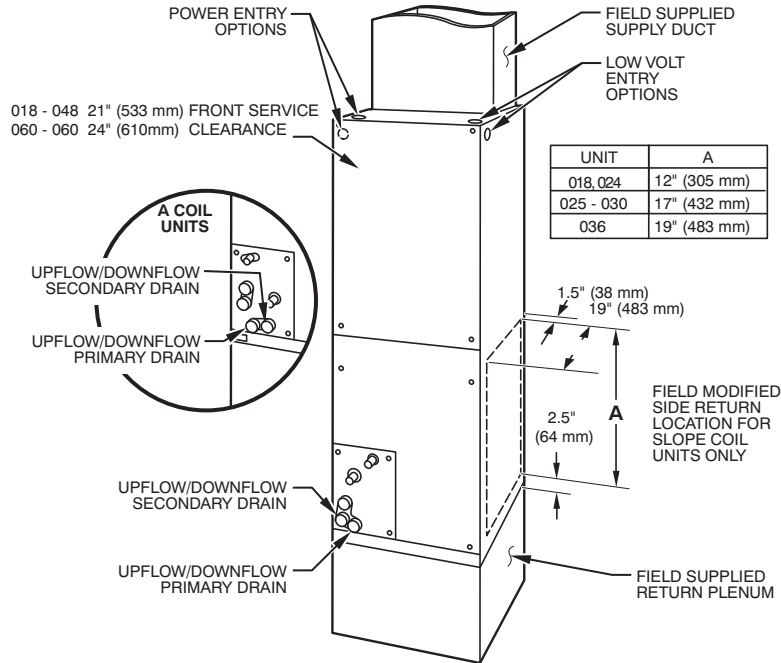

Fig. 1 – Slope Coil Unit in Upflow Application

A07565

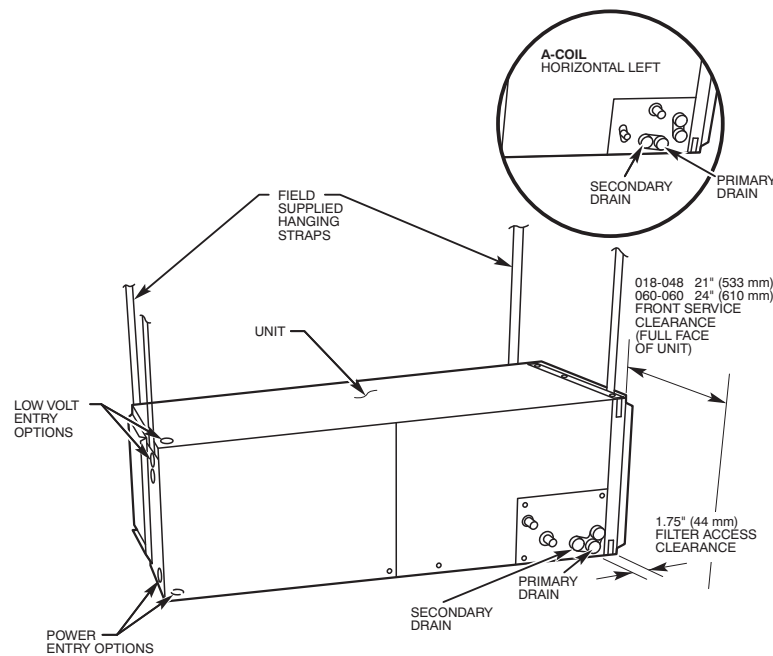

Fig. 2 – Slope Coil in Horizontal Left Application (Factory Configuration)

A07566

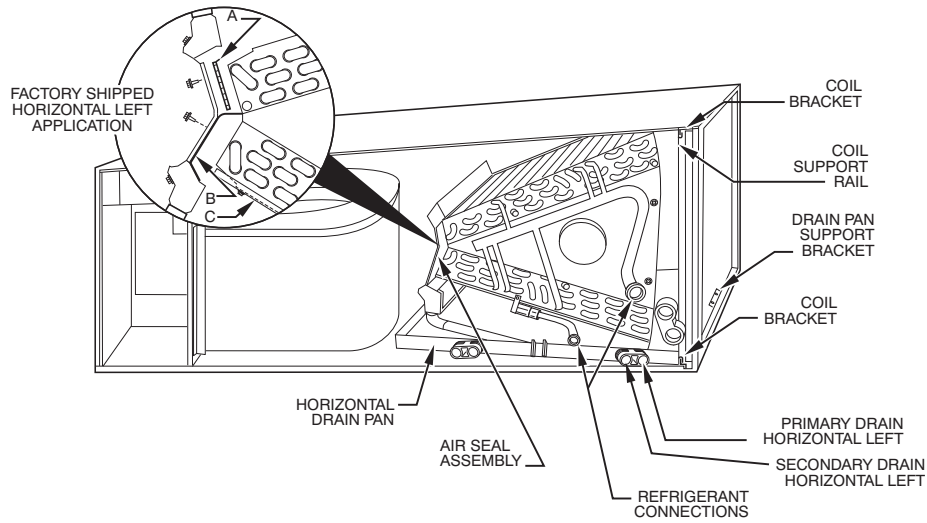

Fig. 3 – A-Coil in Horizontal Left Application (Factory Configuration)

A00072

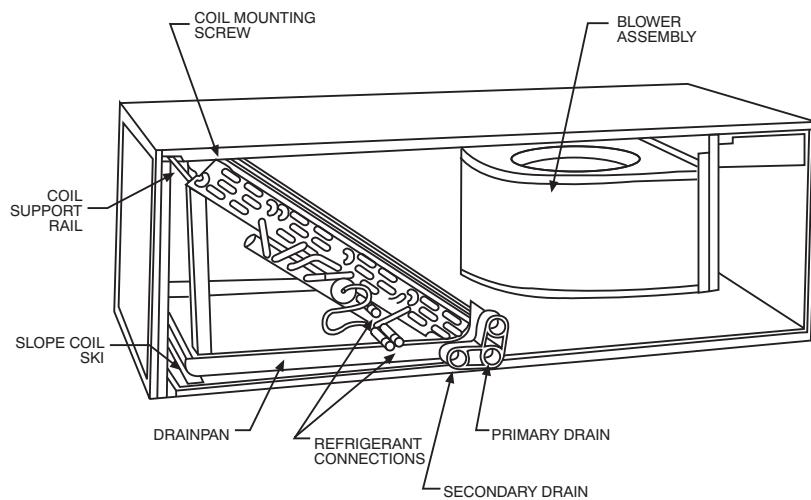

Fig. 4 – Conversion for Horizontal Right Applications - Slope Coil

A03001

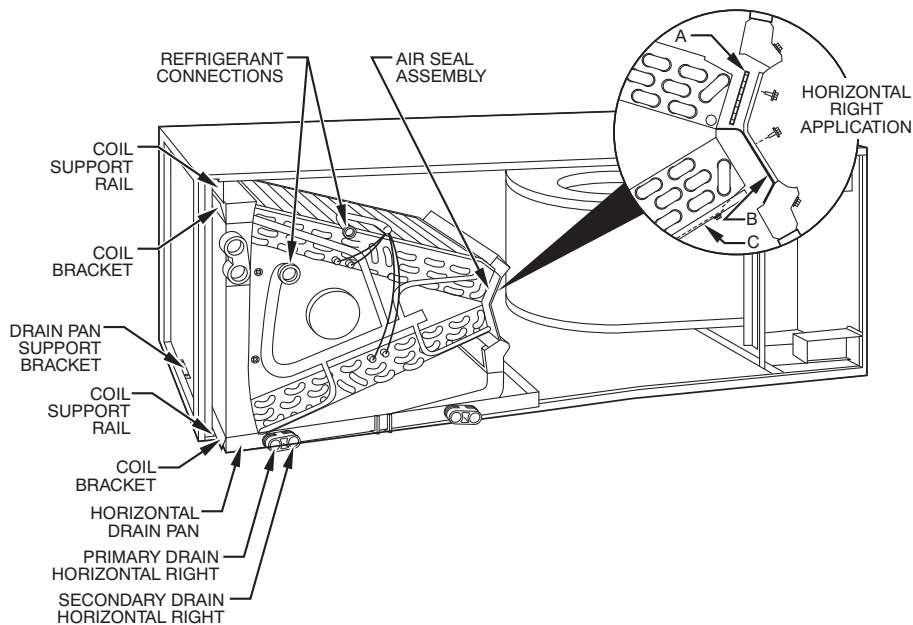

Fig. 5 – Conversion for Horizontal Right Applications - A-Coil

A00071

Downflow Installation

In this application, field conversion of the evaporator is required using accessory downflow kit along with an accessory base kit. Use fireproof resilient gasket, 1/8 to 1/4-in (3 to 6 mm) thick, between duct, unit, and floor.

CAUTION

PRODUCT OR PROPERTY DAMAGE HAZARD

Failure to follow this caution may result in product or property damage. The conversion of the fan coil to downflow requires special procedures for the condensate drains on both A-coil and Slope-coil units. The vertical drains have an overflow hole between the primary and secondary drain holes. This hole is plugged for all applications except downflow, and must be used for downflow. During conversion process, remove plastic cap covering vertical drains only and discard. Remove plug from overflow hole and discard. At completion of downflow installation, caulk around vertical pan fitting to door joint to retain low air leak performance of the unit.

NOTE: To convert units for downflow applications, refer to Installation Instructions supplied with kit for proper installation. For slope fan coils, use kit Part No. KFADC0201SLP. For A-coils, use kit Part No. KFADC0401ACL. Use fireproof resilient gasket, 1/8 to 1/4-in (3 to 6 mm) thick, between duct, unit, and floor.

NOTE: Gasket kit number KFAHD0101SLP is also required for all downflow applications to maintain low air leak/low sweat performance.

Horizontal Installation

Units must not be installed with access panels facing up or down. All other units are factory built for horizontal left installation (Fig. 2 and Fig. 3). When suspending unit from ceiling, dimples in casing indicate suitable location of screws for mounting metal support straps (Fig. 2).

For horizontal applications having high return static and humid return air, the Water Management Kit, KFAHC0125AAA, may need to be used to assist in water management.

NOTE: Modular units can be disassembled and components moved separately to installation area for reassembly. This process accommodates small scuttle holes and limiting entrances to installation sites (Fig. 6).

CAUTION

PROPERTY DAMAGE HAZARD

Failure to follow this caution may result in product or property damage. For optimum condensate drainage performance in horizontal installations, unit should be leveled along its length and width.

Horizontal Right Conversion of Units with Slope Coils

NOTE: Gasket kit number KFAHD0101SLP is required for horizontal slope coil conversion to maintain low air leak/low sweat performance.

1. Remove blower and coil access panels and fitting panel (Fig. 5).
2. Remove coil mounting screw securing coil assembly to right side casing flange.
3. Remove coil assembly.
4. Lay fan coil on its right side and reinstall coil assembly with condensate pan down (Fig. 4).
5. Attach coil to casing flange using previously removed coil mounting screw.
6. Make sure pan cap in fitting door is properly seated on fitting door to retain low air leak rating of the unit.
7. Add gaskets from kit - KFAHD.

8. Align holes with tubing connections and condensate pan connections. Reinstall access panels and fitting panel.
9. Make sure liquid and suction tube grommets are in place to prevent air leaks and cabinet sweating. Install grommets after brazing.

Horizontal Right Conversion of Units with A-Coils

1. Remove blower and coil access panels (Fig. 5).
2. Remove metal clip securing fitting panel to condensate pan. Remove fitting panel.
3. Remove 2 snap-in clips securing A-coil in unit.
4. Slide coil and pan assembly out of unit.
5. Remove horizontal drain pan support bracket from coil support rail on left side of unit and reinstall on coil support rail on right side of unit (Fig. 7).
6. Convert air seal assembly for horizontal right.
 - a. Remove air seal assembly from coil by removing 4 screws (Fig. 5).
 - b. Remove air splitter (B) from coil seal assembly by removing 3 screws (Fig. 3 inset).
 - c. Remove filler plate (A) and install air splitter (B) in place of filler plate.
 - d. Install filler plate (A) as shown in horizontal right application.
 - e. Remove condensate troughs (C) and install on opposite tube sheets.
 - f. Install hose onto plastic spout.
7. Install horizontal pan on right side of coil assembly.
8. Slide coil assembly into casing. Be sure coil bracket on each corner of vertical pan engages coil support rails.
9. Reinstall 2 snap-in clips to correctly position and secure coil assembly in unit. Be sure clip with large offsets is used on right side of unit to secure horizontal pan.
10. Remove two oval fitting caps from left side of the coil, access panel, and fitting panel.
11. Remove insulation knockouts on right side of coil access panel.
12. Remove 2 oval coil access panel plugs and reinstall into holes on left side of coil access panel and fitting panel.
13. Install condensate pan fitting caps (from Step 10) in right side of coil door making sure that cap snaps and seats cleanly on back side of the coil door. Make sure no insulation interferes with seating of cap.
14. Reinstall access and fitting panels, aligning holes with tubing connections and condensate pan connections. Be sure to reinstall metal clip between fitting panel and vertical condensate pan.
15. Make sure liquid and suction tube grommets are in place to prevent air leaks and cabinet sweating.

Manufactured and Mobile Home Housing Applications

1. Fan coil unit must be secured to the structure using field-supplied hardware.
2. Allow a minimum of 24-in (610 mm) clearance from access panels.
3. Recommended method of securing for typical applications:
 - a. If fan coil is away from wall, attach pipe strap to top of fan coil using no. 10 self-tapping screws. Angle strap down and away from back of fan coil, remove all slack, and fasten to wall stud of structure using 5/16-in. lag screws. Typical both sides of fan coil.
 - b. If fan coil is against wall, secure fan coil to wall stud using 1/8-in (3 mm) thick right-angle brackets. Attach brackets to fan coil using no. 10 self-tapping screws and to wall stud using 5/16-in. lag screws (Fig. 8).

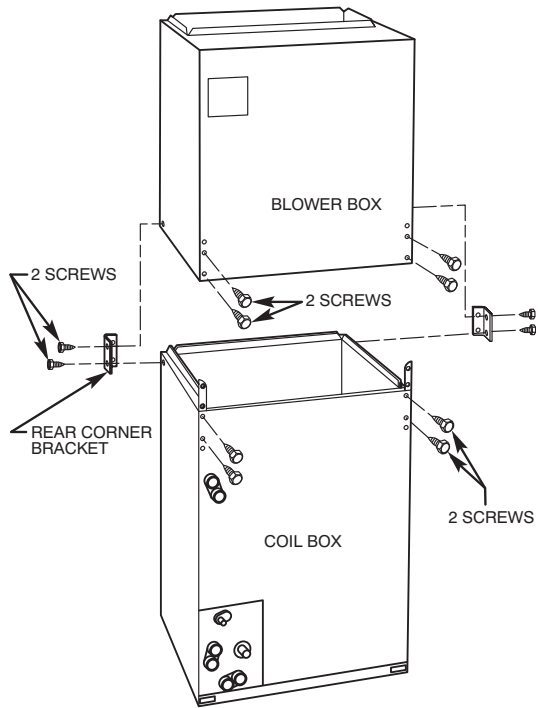

Fig. 6 – Removal of Brackets on Modular Unit

A95293

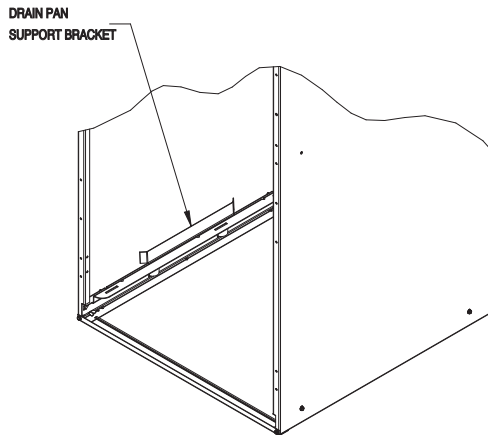

Fig. 7 – Drain Pan Support Bracket

A07571

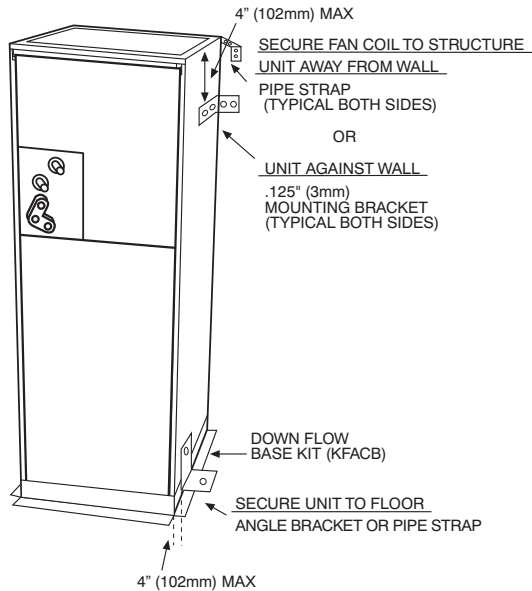

Fig. 8 – Mobile Home or Manufactured Housing Applications

A07567

Air Ducts

Connect supply-air duct over the outside of 3/4-in (19 mm) flanges provided on supply-air opening. Secure duct to flange, using proper fasteners for type of duct used, and seal duct-to-unit joint. If return-air flanges are required, install factory-authorized accessory kit.

Use flexible connectors between ductwork and unit to prevent transmission of vibration. When electric heater is installed, use heat-resistant material for flexible connector between ductwork and unit at discharge connection. Ductwork passing through unconditioned space must be insulated and covered with vapor barrier.

Units equipped with 20-30kW electric heaters require a 1-in (25 mm) clearance to combustible materials for the first 36-in (914 mm) of supply duct.

Duct Work Acoustical Treatment

Metal duct systems that do not have a 90 degree elbow and 10 feet of main duct before first branch takeoff may require internal acoustical insulation lining. As an alternative, fibrous duct work may be used if constructed and installed in accordance with the latest edition of SMACNA construction standard on fibrous glass ducts. Both acoustical lining and fibrous duct work shall comply with National Fire Protection Association as tested by UL Standard 181 for Class 1 air ducts.

Electrical Connections

PF4M units from the factory protect the low voltage circuit with a 3 amp automotive type fuse in-line on the wire harness and Does Not contain a circuit board. Motor speeds and time delay function are built into the motor ([Minimum CFM and Motor Speed Selection on p7](#)).

When a factory-approved accessory control package has been installed, check all factory wiring per unit wiring diagram and inspect factory wiring connections to be sure none were loosened in transit or installation. If a different control package is required, see unit rating plate.

Before proceeding with electrical connections, make certain that supply voltage, frequency, phase, and ampacity are as specified on the unit rating plate. See unit wiring label for proper field high- and low-voltage wiring. Make all electrical connections in accordance with the NEC and any local codes or ordinances that may apply. Use copper wire only.

The unit must have a separate branch electric circuit with a field-supplied disconnect switch located within sight from, and readily accessible from, the unit.

On units with a factory-installed disconnect with pull-out removed, service and maintenance can be safely performed on only the load side of the control package.

⚠ WARNING

ELECTRICAL SHOCK OR UNIT DAMAGE HAZARD

Failure to follow this warning could result in personal injury, death, and/or unit damage.

If a disconnect switch is to be mounted on unit, select a location where drill and fasteners will not contact electrical or refrigeration components.

⚠ WARNING

ELECTRICAL SHOCK HAZARD

Failure to follow this warning could result in personal injury or death.

Field wires on the line side of the disconnect found in the fan coil unit remain live, even when the pull-out is removed. Service and maintenance to incoming wiring cannot be performed until the main disconnect switch (remote to the unit) is turned off.

Line Voltage Connections

If unit contains an accessory electric heater, remove and discard power plug from fan coil and connect male plug from heater to female plug from unit wiring harness. (See Electric Heater Installation Instructions.)

For units without electric heat:

1. Connect 208/230V power leads from field disconnect to yellow and black stripped leads.
2. Connect ground wire to unit ground lug.

NOTE: Units installed without electric heat should have a field-supplied sheet metal block-off plate covering the heater opening. This will reduce air leakage and formation of exterior condensation.

24V Control System

Connection To Unit

Wire low voltage in accordance with wiring label on the blower (Fig. 9 thru Fig. 12). Use no. 18 AWG color-coded, insulated (35°C minimum) wire to make the low-voltage connections between the thermostat, the unit, and the outdoor equipment. If the thermostat is located more than 100-ft (30 m) from the unit (as measured along the low-voltage wire), use no. 16 AWG color-coded, insulated (35°C minimum) wire. All wiring must be NEC Class 2 and must be separated from incoming power leads.

Refer to outdoor unit wiring instructions for any additional wiring procedure recommendations.

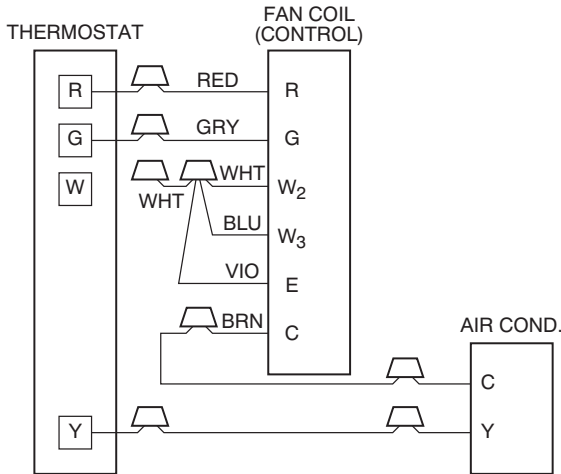

Fig. 9 – Wiring Layout Air Conditioning Unit (Cooling Only)

A94058

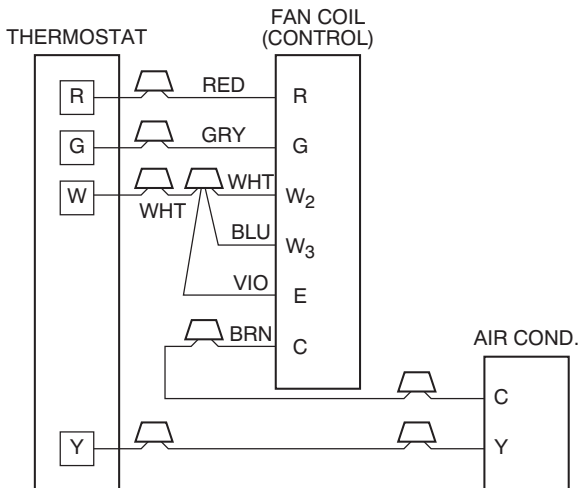

Fig. 10 – Wiring Layout Air Conditioning Unit (Cooling and 1-Stage Heat)

A94059

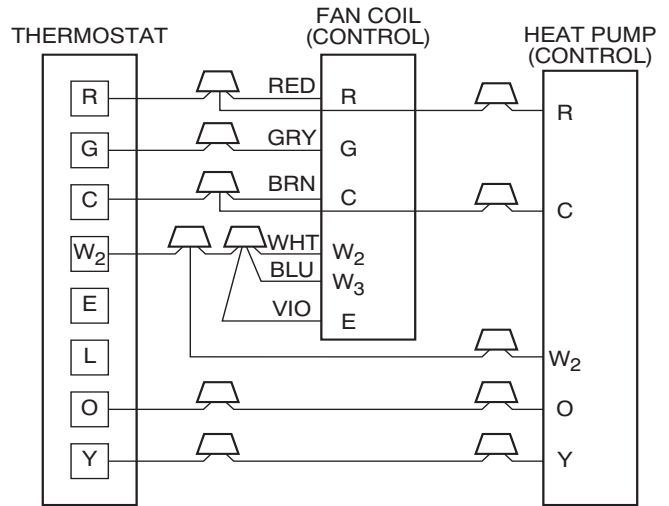

Fig. 11 – Wiring Layout Heat Pump Unit (Cooling and 2-Stage Heat with No Outdoor Thermostat)

A94060

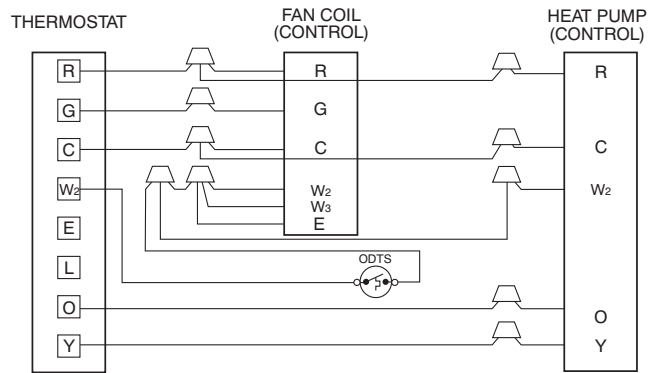

Fig. 12 – Wiring Layout Heat Pump Unit (Cooling and 2-Stage Heat for Manufactured Housing)

A03088

Transformer Information

Transformer is factory wired for 230V operation. For 208V applications, disconnect the black wire from the 230V terminal on transformer and connect it to the 208V terminal (Fig. 13).

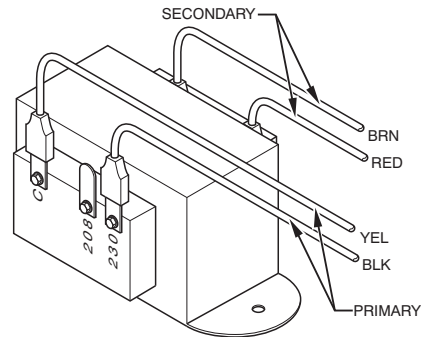

Fig. 13 – Transformer Connections

A05182

Heater Staging

If electric heat staging is required, a multi-stage heating room thermostat is required. Consult your equipment supplier for a suitable thermostat.

Manufactured Housing

In manufactured housing applications, the Code of Federal Regulations, Title 24, Chapter XX, Part 3280.714 requires that supplemental electric heat be locked out at outdoor temperatures above 40°F (4°C), except for a heat pump defrost cycle. Refer to Fig. 12 for typical low voltage wiring with outdoor thermostat.

Ground Connections

NOTE: Use UL listed conduit and conduit connectors for connecting supply wire(s) to unit to obtain proper grounding. Grounding may also be accomplished by using grounding lugs provided in control box.

! WARNING

ELECTRICAL SHOCK HAZARD

Failure to establish uninterrupted or unbroken ground could result in personal injury and/or death.

According to NEC, NFPA 70, and local codes, the cabinet must have an uninterrupted or unbroken ground to minimize personal injury if an electrical fault should occur. The ground may consist of electrical wire or metal conduit when installed in accordance with existing electrical codes. If conduit connection uses reducing washers, a separate ground wire must be used.

Minimum CFM and Motor Speed Selection

The fan speed selection is done at the motor connector. Units with or without electric heaters require a minimum CFM. Refer to the unit wiring label to ensure that the fan speed selected is not lower than the minimum fan speed indicated.

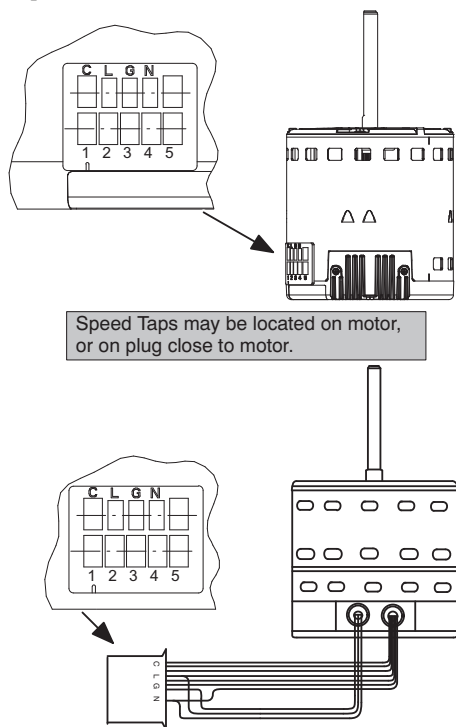

Fig. 14 – Motor Speed Selection

A11048

Table 1 – Fan Speed Selection

Tap	Speed	Off Delay
Tap 1	Low	90 sec off delay
Tap 2	Medium	90 sec off delay
Tap 3	High	90 sec off delay
Tap 4	Electric heat †	0 sec off delay
Tap 5	Max ‡	0 sec off delay

† electric heat airflow is same CFM as Tap 3, except 0 sec off delay
 ‡ high static applications, see airflow tables for max airflow

To change motor speeds disconnect the BLUE fan lead from motor connector terminal #2 (factory default position) and move to desired speed-tap; 1, 2, 3, or 5.

Speed-taps 1, 2, and 3 have a 90-second blower off time delay pre-programmed into the motor. Speed-tap 4 is used for electric heat only (with 0 second blower time delay) and the WHITE wire should

remain on tap 4. Speed-tap 5 is used for high static applications, but has a 0 second blower time delay pre-programmed into the motor. See Airflow Performance tables for actual CFM. Also see Fig. 14 for motor speed selection location.

NOTE: In low static applications, lower motor speed tap should be used to reduce possibility of water being blown off coil.

Refrigerant Tubing Connection and Evacuation

Use accessory tubing package or field-supplied tubing of refrigerant grade. Suction tube must be insulated. Do not use damaged, dirty, or contaminated tubing because it may plug refrigerant flow-control device. ALWAYS evacuate the coil and field-supplied tubing to 500 microns before opening outdoor unit service valves.

! CAUTION

PRODUCT DAMAGE HAZARD

Failure to follow this caution may result in product or property damage. A brazing shield **MUST** be used when tubing sets are being brazed to the unit connections to prevent damage to the unit surface and condensate pan fitting caps.

Units have sweat suction and liquid tube connections. Make suction tube connection first.

1. Cut tubing to correct length.
2. Insert tube into sweat connection on unit until it bottoms.
3. Braze connection using silver bearing or non-silver bearing brazing materials. Do not use solder (materials which melt below 800°F / 427°C). Consult local code requirements.
4. Evacuate coil and tubing system to 500 microns using a deep vacuum method.

! CAUTION

PRODUCT DAMAGE HAZARD

Failure to follow this caution may result in product or property damage. Wrap a wet cloth around rear of fitting to prevent damage to TXV and factory-made joints.

Refrigerant Flow-Control Device

The PF4M units come equipped with a R-410A refrigerant TXV. Always use outdoor units designed to match indoor fan coil applications.

! CAUTION

PRODUCT OPERATION HAZARD

Failure to follow this caution may result in improper product operation. If using a TXV in conjunction with a single-phase reciprocating compressor, a compressor start capacitor and relay are required. Consult outdoor unit pre-sale literature for start assist kit part number.

Condensate Drains

To connect drains, the cap openings must be removed. Use a knife to start the opening near the tab and using pliers, pull the tab to remove the disk. Clean the edge of the opening if necessary and install the condensate line. Finally caulk around the lines where they exit the fitting to retain the low leak rating of the unit.

Units are equipped with primary and secondary 3/4-in. FPT drain connections. For proper condensate line installations see Fig. 1 thru Fig. 5. To prevent property damage and achieve optimum drainage

performance, BOTH primary and secondary drain lines should be installed and include properly-sized condensate traps (Fig. 15 and Fig. 17). Factory-approved condensate traps are available. It is recommended that PVC fittings be used on the plastic condensate pan. Finger-tighten plus 1-1/2 turns. Do not over-tighten. Use pipe dope.

NOTE: When connecting condensate drain lines, avoid blocking filter access panel, thus preventing filter removal. After connection, prime both primary and secondary condensate traps.

! CAUTION

PRODUCT DAMAGE HAZARD

Failure to follow this caution may result in product or property damage. Use only full size P-traps in the condensate line (Fig. 15). Shallow running traps are inadequate and DO NOT allow proper condensate drainage (Fig. 16).

! CAUTION

UNIT OR PROPERTY DAMAGE HAZARD

Failure to follow this warning caution may result in product or property damage. The conversion of the fan coil to downflow requires special procedures for the condensate drains on both A-coil and Slope-coil units. The vertical drains have an overflow hole between the primary and secondary drain holes. This hole is plugged for all applications except downflow, and must be used for downflow. During conversion process, remove plastic cap covering vertical drains only and discard. Remove plug from overflow hole and discard. At completion of downflow installation, caulk around vertical pan fitting to door joint to retain low air leak performance of the unit.

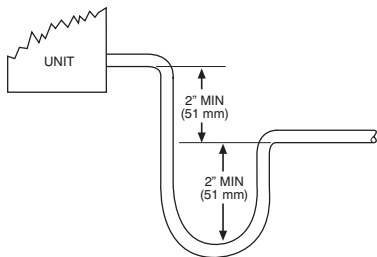

Fig. 15 – Recommended Condensate Trap

A03002



Fig. 16 – Insufficient Condensate Trap

A03013

NOTE: If unit is located in or above a living space where damage may result from condensate overflow, a field-supplied, external condensate pan should be installed underneath the entire unit, and a secondary condensate line (with appropriate trap) should be run from the unit into the pan. Any condensate in this external condensate pan should be drained to a noticeable place. As an alternative to using an external condensate pan, some localities may allow the use of a separate 3/4-in (19 mm) condensate line (with appropriate trap) to a place where the

condensate will be noticeable. The owner of the structure must be informed that when condensate flows from the secondary drain or external condensate pan, the unit requires servicing or water damage will occur.

Install traps in the condensate lines as close to the coil as possible (Fig. 17). Make sure that the outlet of each trap is below its connection to the condensate pan to prevent condensate from overflowing the drain pan. Prime all traps, test for leaks, and insulate traps if located above a living area. Condensate drain lines should be pitched downward at a minimum slope of 1-in (25 mm) for every 10-ft (3 m) of length. Consult local codes for additional restrictions or precautions.

Accessories

Humidifier

Connect humidifier and humidistat to fan coil unit as shown in Fig. 18 and Fig. 19. The cooling lockout relay is optional.

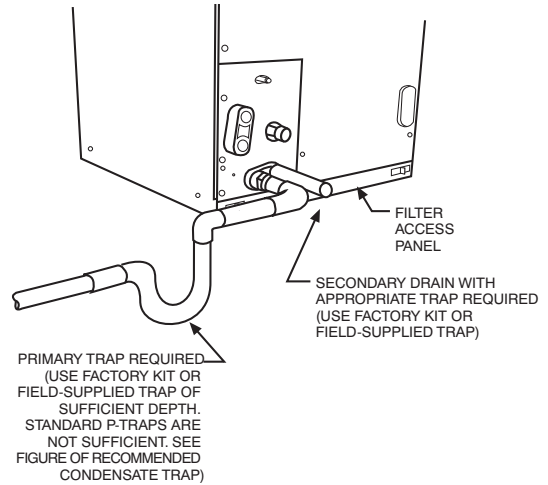

Fig. 17 – Condensate Drain

A03003

Sequence of Operation

Continuous Fan

Thermostat closes R to G. G energizes circuit to indoor blower motor. When G is de-energized, there is a 90-second delay before relay opens.

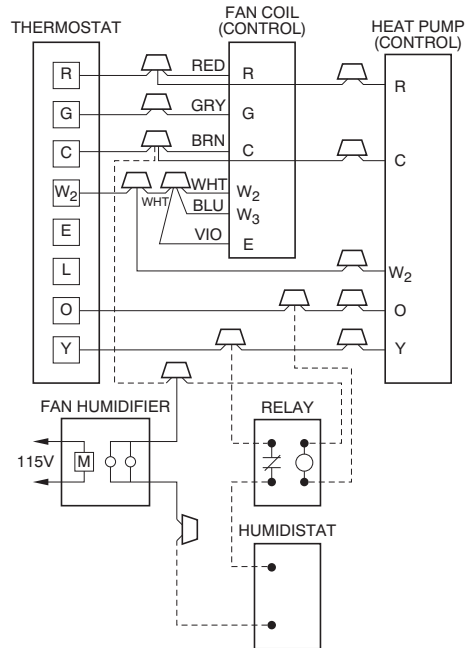

Fig. 18 – Wiring Layout of Humidifier to Heat Pump

A95294

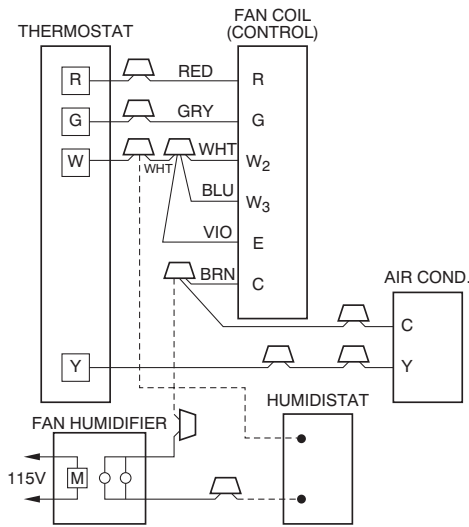

Fig. 19 – Wiring Layout of Humidifier to Fan Coil with Electric Heat

A95295

Cooling Mode

Thermostat energizes R to G, R to Y, and R to O (heat pump only). G energizes circuit to indoor blower motor. When G is de-energized, there is a 90-second delay before fan relay opens.

Heat Pump Heating with Auxiliary Electric Heat

Thermostat energizes R to G, R to Y, and R to W. G energizes circuit to indoor blower motor. W energizes electric heat relay(s) which completes circuit to heater element(s). When W is de-energized, electric heat relay(s) open, turning off heater elements. When G is de-energized there is a 90-second delay before fan relay opens.

Electric Heat or Emergency Heat Mode

Thermostat closes R to W. W energizes electric heat relay(s) which completes circuit to heater element(s). Blower motor is energized through speed tap 4 (white wire). When W is de-energized, electric heat relay(s) opens.

Start-Up Procedures

Refer to outdoor unit Installation Instructions for system start-up instructions and refrigerant charging method details.

⚠ CAUTION

PRODUCT DAMAGE HAZARD

Failure to follow this caution may result in poor unit performance and/or product damage.

Never operate unit without a filter. Factory authorized filter kits may be used when locating the filter inside the unit. For those applications where access to an internal filter is impractical, a field-supplied filter must be installed in the return air duct system.

Care and Maintenance

To continue high performance and minimize possible equipment failure, it is essential that periodic maintenance be performed on this equipment. Consult your local dealer as to the proper frequency of maintenance contract.

The ability to properly perform maintenance on this equipment requires certain mechanical skills and tools. If you do not possess these, contact your dealer for maintenance. The only consumer service recommended or required is filter replacement or cleaning on a monthly basis.

Table 2 – Air Delivery Performance Correction Component Pressure Drop (in. wc) at Indicated Airflow (Dry-to-Wet Coil)

UNIT SIZE	CFM															
	500	600	700	800	900	1000	1100	1200	1300	1400	1500	1600	1700	1800	1900	2000
018, 019	0.034	0.049	0.063	--	--	--	--	--	--	--	--	--	--	--	--	--
024	0.034	0.049	0.063	0.076	0.089	--	--	--	--	--	--	--	--	--	--	--
025	0.015	0.026	0.038	0.049	0.059	--	--	--	--	--	--	--	--	--	--	--
030, 031	--	--	--	0.049	0.059	0.070	0.080	--	--	--	--	--	--	--	--	--
036	--	--	--	--	--	0.070	0.080	0.090	0.099	--	--	--	--	--	--	--
037	--	--	--	--	--	0.055	0.064	0.073	0.081	--	--	--	--	--	--	--
042, 043	--	--	--	--	--	--	--	0.049	0.056	0.063	0.070	--	--	--	--	--
048	--	--	--	--	--	--	--	--	--	0.063	0.070	0.076	0.083	0.090	--	--
049	--	--	--	--	--	--	--	--	--	0.038	0.043	0.049	0.054	0.059	--	--
060	--	--	--	--	--	--	--	--	--	--	--	0.049	0.054	0.059	0.065	0.070
061	--	--	--	--	--	--	--	--	--	--	--	0.027	0.031	0.035	0.039	0.043

Table 3 – Factory-Installed Filter Static Pressure Drop (in. wc)

SIZE	CFM								
	400	600	800	1000	1200	1400	1600	1800	2000
018, 019	0.020	0.044	0.075	-	-	-	-	-	-
024 - 031	-	0.022	0.048	0.072	0.100	-	-	-	-
036-049	-	-	-	0.051	0.070	0.092	0.120	0.152	-
060, 061	-	-	-	-	-	-	0.086	0.105	0.130

Table 4 – Electric Heater Static Pressure Drop (in. wc)

Sizes 018 - 037			Sizes 042 - 061		
HEATER ELEMENTS	kW	EXTERNAL STATIC PRESSURE CORRECTION	HEATER ELEMENTS	kW	EXTERNAL STATIC PRESSURE CORRECTION
0	0	+ .02	0	0	+ .04
1	3, 5	+ .01	2	8, 10	+ .02
2	8, 10	0	3	9, 15	0
3	9, 15	- .02	4	20	- .02
4	20	- .04	6	18, 24, 30	- .10

Table 5 – PF4MNP Airflow Performance (CFM)

Model & Size	Blower Speed	0.10	0.20	0.30	0.40	0.50	0.60
PF4MNP 018	Tap 5	767	739	702	669	620	565
	Tap 4	614	569	534	486	436	398
	Tap 3	701	660	616	581	537	499
	Tap 2	614	569	534	486	436	398
	Tap 1	410	350	304	261	228	203
PF4MNP 024 / 025	Tap 5	969	936	892	835	763	676
	Tap 4	826	795	766	743	706	660
	Tap 3	826	795	766	743	706	660
	Tap 2	701	660	616	581	537	499
	Tap 1	617	592	552	507	472	420
PF4MNP 030	Tap 5	1108	1090	1065	1034	1009	974
	Tap 4	1026	1000	969	938	899	865
	Tap 3	1026	1000	969	938	899	865
	Tap 2	909	873	842	799	762	724
	Tap 1	825	795	757	722	674	634
PF4MNP 036	Tap 5	1301	1276	1245	1218	1176	1121
	Tap 4	1227	1191	1169	1143	1105	1074
	Tap 3	1227	1191	1169	1143	1105	1074
	Tap 2	1087	1062	1030	1001	966	930
	Tap 1	1026	1000	969	938	899	865
PF4MNP 042	Tap 5	1560	1544	1507	1464	1424	1358
	Tap 4	1419	1397	1358	1320	1279	1239
	Tap 3	1419	1397	1358	1320	1279	1239
	Tap 2	1249	1220	1184	1142	1093	1052
	Tap 1	1242	1205	1158	1110	1069	1026
PF4MNP 048	Tap 5	1743	1712	1679	1642	1610	1574
	Tap 4	1669	1634	1599	1564	1531	1499
	Tap 3	1669	1634	1599	1564	1531	1499
	Tap 2	1452	1413	1377	1339	1308	1271
	Tap 1	1300	1256	1221	1182	1142	1101
PF4MNP 060	Tap 5	1897	1867	1836	1808	1774	1736
	Tap 4	1817	1785	1757	1724	1693	1655
	Tap 3	1817	1785	1757	1724	1693	1655
	Tap 2	1657	1621	1589	1557	1518	1474
	Tap 1	1443	1412	1377	1332	1286	1243

■ - Shading - Airflow outside 450 cfm/ton.

- Notes:**
1. Airflow based upon dry coil at 230v with factory-approved filter and electric heater (2 element heater sizes 018 through 036, 3 element heater sizes 042 through 061).
 2. Airflow at 208 volts is approximately the same as 230 volts because the multi-tap ECM motor is a constant torque motor. The torque doesn't drop off at the speeds the motor operates.
 3. To avoid potential for condensate blowing out of drain pan prior to making drain trap:
Return static pressure must be less than 0.40 in. wc.
Horizontal applications of 042 - 061 sizes must have supply static greater than 0.20 in. wc.
 4. Airflow above 400 cfm/ton on 048-061 size could result in condensate blowing off coil or splashing out of drain pan.

Table 6 – PF4MNB Airflow Performance (CFM)

Model & Size	Blower Speed	EXTERNAL STATIC (in. wc)					
		0.10	0.20	0.30	0.40	0.50	0.60
PF4MNB 019	Tap 5	776	745	696	660	609	572
	Tap 4	683	644	589	548	494	461
	Tap 3	683	644	589	548	494	461
	Tap 2	631	563	500	443	409	361
	Tap 1	625	524	457	417	367	319
PF4MNB 025	Tap 5	956	920	891	851	816	780
	Tap 4	825	795	757	722	674	634
	Tap 3	825	795	757	722	674	634
	Tap 2	726	695	635	598	543	509
	Tap 1	631	563	500	443	409	361
PF4MNB 031	Tap 5	1189	1151	1104	1050	1003	959
	Tap 4	1041	998	944	886	837	772
	Tap 3	1041	998	944	886	837	772
	Tap 2	924	876	817	752	704	660
	Tap 1	779	693	628	571	526	476
PF4MNB 037	Tap 5	1363	1332	1294	1253	1207	1157
	Tap 4	1237	1206	1160	1121	1070	1013
	Tap 3	1237	1206	1160	1121	1070	1013
	Tap 2	1095	1058	1007	951	888	824
	Tap 1	1014	885	773	673	609	549
PF4MNB 043	Tap 5	1519	1490	1454	1419	1379	1332
	Tap 4	1437	1403	1366	1333	1294	1245
	Tap 3	1437	1403	1366	1333	1294	1245
	Tap 2	1257	1226	1191	1141	1090	1033
	Tap 1	1237	1206	1160	1121	1070	1013
PF4MNB 049	Tap 5	1757	1725	1693	1653	1614	1576
	Tap 4	1664	1626	1593	1552	1517	1477
	Tap 3	1664	1626	1593	1552	1517	1477
	Tap 2	1459	1420	1379	1336	1298	1259
	Tap 1	1301	1241	1195	1150	1102	1039
PF4MNB 061	Tap 5	2030	1995	1961	1927	1888	1842
	Tap 4	1811	1775	1740	1703	1664	1613
	Tap 3	1811	1775	1740	1703	1664	1613
	Tap 2	1665	1632	1593	1556	1507	1453
	Tap 1	1462	1418	1371	1327	1278	1228

■ - Shading - Airflow outside 450 cfm/ton.

- Notes:**
1. Airflow based upon dry coil at 230v with factory-approved filter and electric heater (2 element heater sizes 019 through 037, 3 element heater sizes 043 through 061).
 2. Airflow at 208 volts is approximately the same as 230 volts because the multi-tap ECM motor is a constant torque motor. The torque doesn't drop off at the speeds the motor operates.
 3. To avoid potential for condensate blowing out of drain pan prior to making drain trap:
Return static pressure must be less than 0.40 in. wc.
Horizontal applications of 043 - 061 sizes must have supply static greater than 0.20 in. wc.
 4. Airflow above 400 cfm/ton on 049-061 size could result in condensate blowing off coil or splashing out of drain pan.

NOTES: